

### Sash Knobs

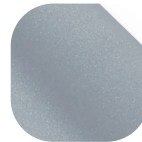

### Features

- Sturdy feel**  
 Solid die cast zinc construction
- Easy to grip**  
 Sculptured ergonomic design
- Wide choice**  
 Available in Classic, Heritage and Architectural Bottom Sash Knobs to suit with the High Security Cam Lock and a anodised Top Sash Knob
- Perfectly matching hardware**  
 Supplied with colour coordinated screws that perfectly matches to the Sash Pull Handle
- Designed for PVCu, Timber and Aluminium sliding windows**  
 To suit all window materials, we have a range of different keeps to suit specific profiles
- Available in the complete range of Hardex finishes**  
 Perfectly matching to the full Fab&Fix range of products



Premium Satin



Hardex Chrome

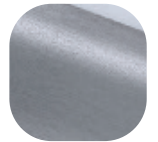

Hardex Graphite



Hardex Bronze

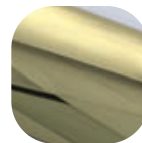

Hardex Gold

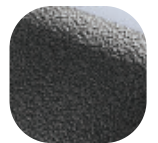

Antique Black



Hardex Pewter



White



Black

### Sash Knobs

#### Ordering Details

Bottom Sash Knob		Part No.	
Finish	Classic	Heritage	Architectural
Hardex Chrome	VHSKCHC01A	VHSKHHC01A	VSKAHC01A
Hardex Bronze	VHSKCHB01A	VSKHHC01A	VSKAHB01A
Hardex Gold	VHSKCHG01A	VSKHHG01A	VSKAHG01A
Hardex Graphite	VSKCGR01A	VSKHGR01A	VSKAGR01A
Hardex Pewter	VSKCPT01	VSKHPT01	VSKAPT01
Antique Black	VSKCAB01A	VSKHAB01A	VSKAAB01A
White	VSKCWH01A	VSKHWH01A	VSKAWH01A
Black	VSKCBK01A	VSKHKB01A	VSKABK01A
Premium Satin	VSKCPS01B	VSKHPS01B	VSKAPS01B

#### Top Sash Knob

Finish	Part No.
Top Sash Knob Satin Anodised	BF-KNB-ANN00

#### Technical Information

##### Corrosion Resistance

Meets the requirements of BS EN 1670:2007 Grade 5 (480 hours)

##### Material Specification

Bottom Sash Knob:	Zinc Die Cast
Coatings:	Hardex Chrome, Hardex Bronze, Hardex Gold, Hardex Graphite, Hardex Pewter, Antique Black, Premium Satin, White and Black.

#### Maintenance

For continued protection of the quality finish and appearance, we advise routine cleaning of all our external hardware. We recommend wiping it with a clean cloth soaked in warm water and mild detergent every month. Please refrain from using heavy-duty cleaners, containing Chlorine or Potassium. Moving parts should also be lightly lubricated using a light non-acidic mineral oil (e.g., "3 in 1") at least twice per year. The product may need to be adjusted and fixings tightened to ensure a satisfactory operation. This procedure is particularly essential if products are used within a 25-mile radius of coastal areas or close proximity to building sites or large industrial areas, where more frequent cleaning may be required to prevent the accumulation of corrosive contaminants.

#### Packaging

Sash Knob: Individually bagged, 100 per box

Classic

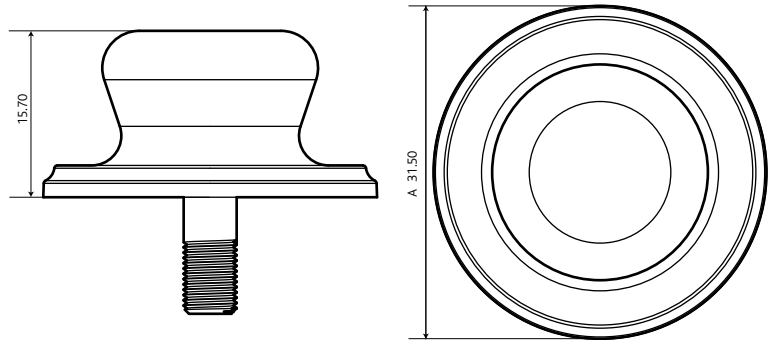

Heritage

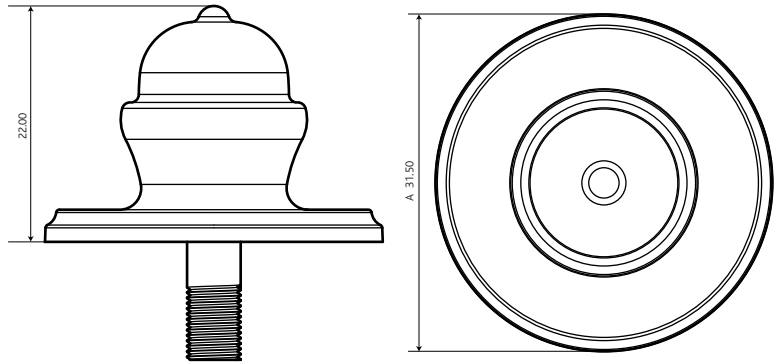

Architectural

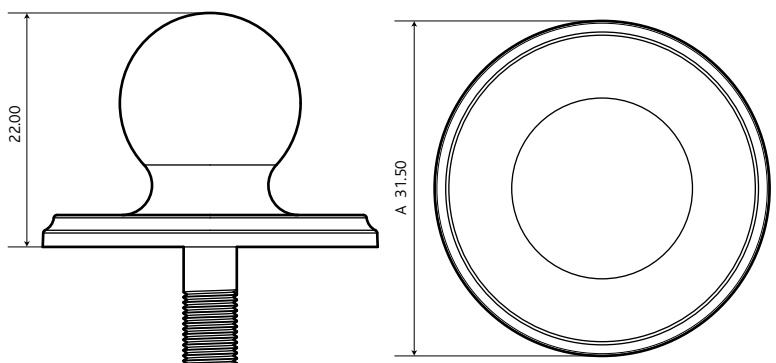

Diagram not to scale.

All dimensions are in mm and are nominal.

Fab&Fix reserves the right to change specification without notice. It is the responsibility of the window manufacturer to ensure that the finished product meets any required safety and performance specification.